

FRAMED SWINGING DOORS INSTALLATION INSTRUCTIONS

IMPORTANT - PRODUCT LIABILITY INFORMATION

Install as illustrated to obtain proper door motion. Failure to follow these instructions may lead to product instability and/or collapse which may result in personal injury or property damage.

1. Install framed swinging doors to previously set up unit using three (3) 1/4-20 x 5/8 Phillips pan head machine screws and three (3) 1/4-20 hex nuts to each side as shown.
2. Level if necessary.

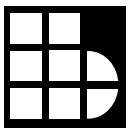
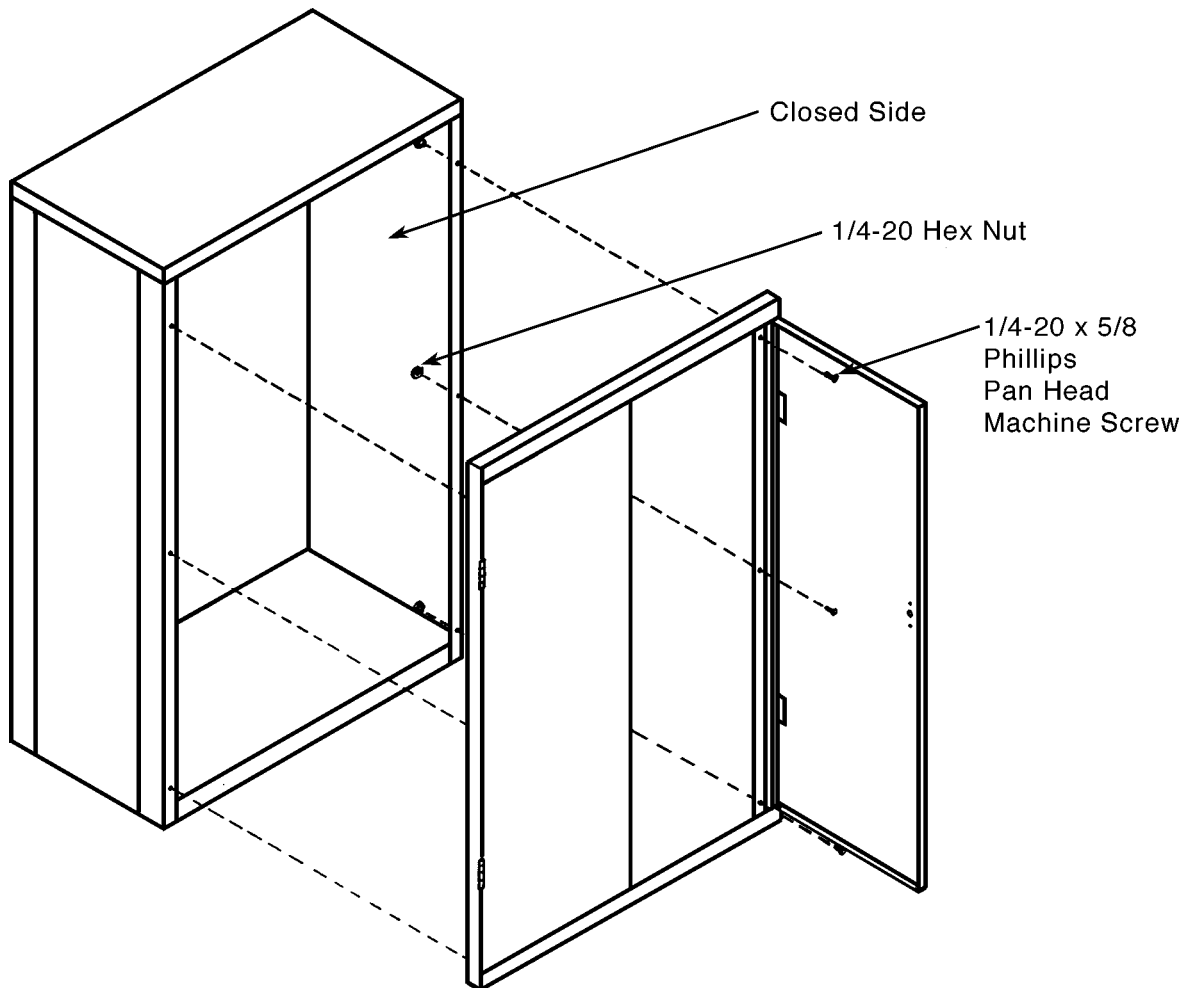

Borroughs

CORPORATION

ISO 9001:2000 Registered

3002 N. BURDICK STREET ■ KALAMAZOO, MI 49004-3483
800-748-0227 ■ FAX: 269-342-4161 ■ www.borroughs.com

02-50230-000B

MARCH 2006

3. Align handle over holes on exterior of right hand door as shown below.
4. Align handle reinforcement over same holes on interior of right hand door and attach with two (2) #8-23 x 5/16 SEMS screws.
5. Insert throw bolts through guides and door slots with drilled-hole ends toward handle reinforcement.
6. With latch bar of cam in horizontal position as shown, place throw bolt holes over studs on underside of cam. Align square hole in cam with square shaft of handle and push cam on shaft.

NOTE: Both throw bolts will be slightly bent over edges of handle reinforcement when properly installed.

7. Install push clip on shaft to secure assembly.

NOTE: It may be necessary to use a mallet and round tube to properly seat push clip.

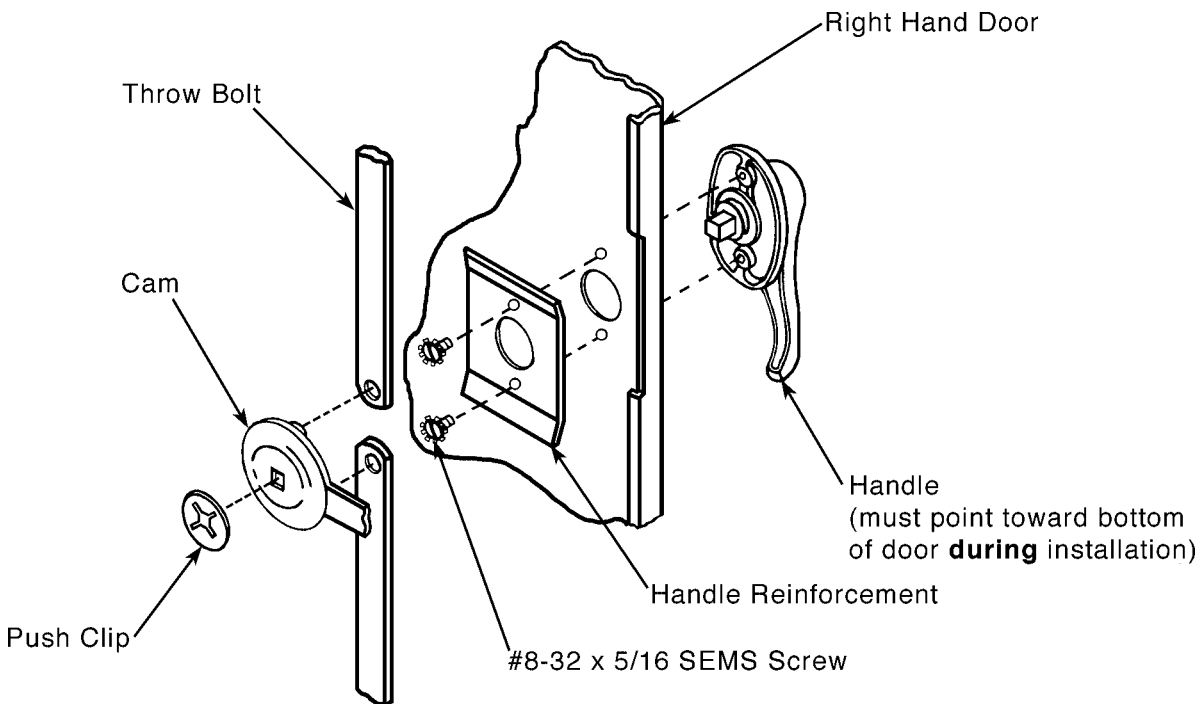

WARRANTY:

The following is the only warranty applicable to the products: the manufacturer warrants that the products are free from defects in material or workmanship when installed, used and serviced in accordance with the manufacturer's recommendations. The manufacturer's only obligation under this warranty shall be to replace any product which is defective in materials within one year, or defective in workmanship within ninety days, from the date of installation. THE FOREGOING WARRANTY IS EXPRESSLY IN LIEU OF ALL OTHER WARRANTIES, EXPRESS OR IMPLIED, INCLUDING ANY WARRANTIES OF MERCHANTABILITY OR FITNESS FOR PURPOSE. The manufacturer shall not be liable for any loss or damage, direct or indirect, resulting from the use or loss of use of the product. This warranty may not be changed except by a written agreement signed by an officer of the manufacturer.