

Box Edge Plus® Steel Shelving Installation Instructions

————— **IMPORTANT** —————
PRODUCT LIABILITY INFORMATION

Read all instructions before proceeding with installation or shelf loading. Vital product information pertaining to proper set-up, safe loading and cautions are included. Failure to follow these instructions may cause shelving failure which may result in personal injury and/or property damage.

**RETAIN THIS MANUAL
FOR FUTURE REFERENCE**

GENERAL INSTRUCTIONS

In preparing for multiple section installations, it is recommended that a floor plan with elevations be available at the job site. It is further recommended that the floor be marked to indicate where the rows will be and where the aisles will be so that the distributed material can be stacked for minimal interference. This will also show where obstructions will occur. The sections may then be erected along the lines so that once the row is in place, the bracing bolts can be tightened and each section will remain square. Rough or uneven floors should be compensated with shims. It is required that sections not be out of plum more than 1" in ten feet or more of height.

BASIC DATA

WIDTHS:

Nominal unit width: 24", 36", 42" or 48"
 Actual beaded post unit width is the nominal width plus $1" \begin{smallmatrix} +1/16" \\ -0" \end{smallmatrix}$
 Actual angle post unit width is the nominal width $\begin{smallmatrix} +1/16" \\ -0" \end{smallmatrix}$
 Actual high-rise post unit width is the nominal width plus $2" \begin{smallmatrix} +1/16" \\ -0" \end{smallmatrix}$

DEPTHS:

Nominal depth: 12", 15", 18", 24", 30", 32" or 36"
 Actual beaded post unit depth is the nominal depth plus $15/32" \begin{smallmatrix} +1/32" \\ -0" \end{smallmatrix}$ with beaded post in front and angle post in back
 Actual angle post unit depth is the nominal depth $\begin{smallmatrix} +1/32" \\ -0" \end{smallmatrix}$
 Actual high-rise post unit depth is the nominal depth plus $15/32" \begin{smallmatrix} +1/32" \\ -0" \end{smallmatrix}$ with high-rise post in front and angle post in back
 Actual high-rise post unit depth is the nominal depth plus $1-15/16" \begin{smallmatrix} +1/16" \\ -0" \end{smallmatrix}$ with high-rise posts in front and in back

HEIGHTS:

Nominal height: One foot increments from 3'3" to 16'3"
 Actual height is the nominal height minus $1/4" \pm 1/16"$
 NOTE: Unit anchoring is recommended when the height to depth ratio exceeds 4.
 EXAMPLE: 7'3" high x 18" deep unit has a height to depth ratio of 4.873 and should be anchored to a firm restraint such as a floor, wall or tied overhead across the aisle to an opposite upright assembly.

LENGTH OF RUN:

Actual length of beaded post shelving run in nominal unit width $\begin{smallmatrix} +1/16" \\ -0" \end{smallmatrix}$ per unit plus 1/2" for each row end.
 Actual length of angle post shelving run in nominal unit width $\begin{smallmatrix} +1/16" \\ -0" \end{smallmatrix}$ per unit
 Actual length of high-rise post shelving run is nominal unit width $\begin{smallmatrix} +1/16" \\ -0" \end{smallmatrix}$ per unit plus 1" for each row end.

CLEAR SHELF OPENING:

Actual clear opening between beaded posts is the nominal width minus 1"
 Actual clear opening between angle posts is the nominal width minus 2"
 Actual clear opening between high-rise posts is the nominal width minus 2"
 Vertical clearance between shelves is equal to center-to-center shelf spacing minus 1-7/32"

VERTICAL ADJUSTMENT:

All shelves are adjustable on 1-1/2" centers

SHELF CAPACITIES

Size	BOX EDGE PLUS® 1 Shelf Capacity	BOX EDGE PLUS® 2 Shelf Capacity	BOX EDGE PLUS® 3 Shelf Capacity
24" x 12"	600 lbs.		
36" x 12"	600 lbs.	800 lbs.	1100 lbs.
42" x 12"		600 lbs.	1000 lbs.
48" x 12"	400 lbs.	500 lbs.	800 lbs.
36" x 15"	600 lbs.	800 lbs.	1100 lbs.
42" x 15"		600 lbs.	1000 lbs.
48" x 15"		500 lbs.	800 lbs.
24" x 18"	600 lbs.		
36" x 18"	600 lbs.	800 lbs.	1200 lbs.
42" x 18"		600 lbs.	1000 lbs.
48" x 18"	400 lbs.	500 lbs.	800 lbs.
24" x 24"	600 lbs.		
36" x 24"	600 lbs.	800 lbs.	1200 lbs.
42" x 24"		600 lbs.	1000 lbs.
48" x 24"	400 lbs.	500 lbs.	800 lbs.
36" x 30"		600 lbs.	900 lbs.
42" x 30"		600 lbs.	1000 lbs.
48" x 30"		500 lbs.	750 lbs.
42" x 32"	300 lbs.	650 lbs.	1000 lbs.
36" x 36"		400 lbs.	600 lbs.
42" x 36"		450 lbs.	600 lbs.
48" x 36"		450 lbs.	700 lbs.

IMPORTANT:

Wall, floor or top tie anchoring is recommended for units when the height to depth ratio exceeds 4.

Example: A 7'84" high x 18" deep unit has a height to depth ratio of 4.67 and should be attached to a firm restraint, such as a floor, wall or tied overhead across the aisle to an opposite upright assembly.

NOTE:

For more specific information on each individual component, please call our Customer Service Department at 800-748-0227 and ask for the booklet "Box Edge Plus® Steel Shelving Detail Sheets".

SHELVING PARTS IDENTIFICATION

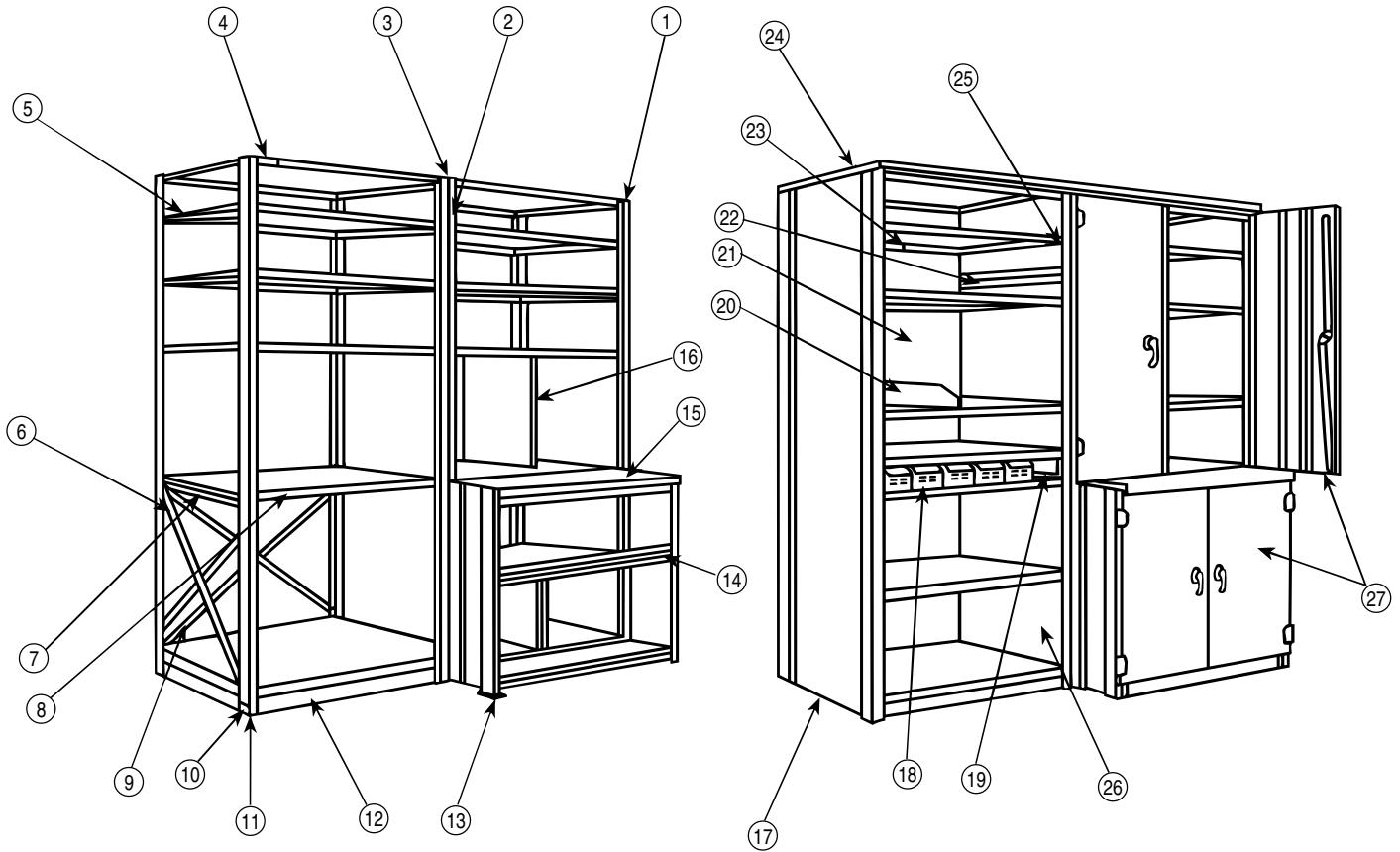

- | | | |
|------------------------------------|--------------------------------------|---|
| 1 Angle Post | 10 ... Post Foot Angle | 19 ... Shelf Box Guide |
| 2 Post Cover - Type 2 | 11 ... Post Cover - Type 1 | 20 ... Angle Shelf Divider |
| 3 Angle Post (2) | 12 ... Base Strip | 21 ... Shelving Back |
| 4 Face Brace | 13 ... Front Foot Plate | 22 ... Flush Bar |
| 5 Box Edge Plus® Shelf | 14 ... Bin Front | 23 ... Back Clip |
| 6 Side Cross Brace | 15 ... Ledge Top | 24 ... Cornice Top |
| 7 Side Shelf Support | 16 ... Fixed Shelf Divider | 25 ... Shelf Bracket Clip |
| 8 Label Holder | 17 ... Angle Post Closed Side | 26 ... Angle Post Closed Side and Angle Post (2) |
| 9 Back Cross Brace | 18 ... Shelf Box | 27 ... Framed Swing Doors |

WARRANTY

Borroughs Corporation extends to the original purchaser from the date of purchase a 5-year limited warranty against manufacturing defects in material and workmanship.

If a Borroughs product fails to perform because of a manufacturing defect, Borroughs will examine it. If found defective, it will be repaired or replaced at our option.

This warranty applies only to Borroughs products acquired directly from Borroughs Corporation or from Authorized Borroughs Dealers.

This warranty does not apply to any product which has been subject to misuse, negligence, or accident; has been damaged in shipment, storage, or installation; has been misapplied or has been modified or repaired by unauthorized persons or been repaired with non-standard Borroughs replacement parts. This

warranty specifically excludes claims for indirect, incidental, or consequential damages arising in any way from a product defect. This warranty is exclusive, and exists in lieu of all other warranties, either expressed or implied.

This warranty give you specific legal rights; you may also have other rights which may vary from state to state.

To obtain warranty service, contact your Borroughs Selling Dealer. You must make a written claim. Provide a copy of your purchase record and a written description of the warranty problem with your claim. If you are unable to contact your Dealer, contact: Borroughs Corporation, Customer Service Manager, 3002 N. Burdick Street, Kalamazoo, MI 49004-3483.

OPEN TYPE SHELVING

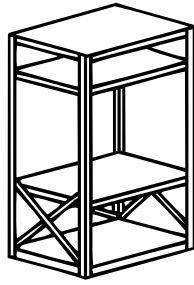

STEP 1 SWAY BRACE ASSEMBLY

After the material has been distributed to the proper location, assemble all sway braces by loosely bolting two matched pieces together at the center.

Assemble side sway braces with 1/4-20 x 3/4" hex head cap screws and hex nuts.

Assemble rear sway braces with 1/4-20 x 5/8" hex head cap screws and hex nuts.

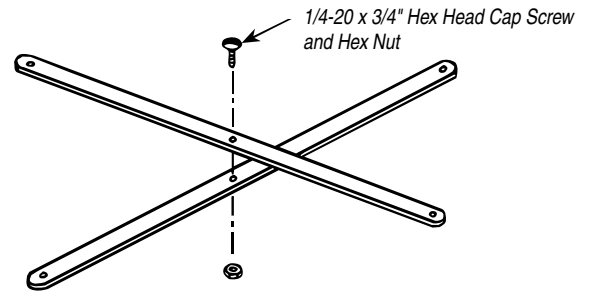

STEP 2 ROW ENDS UPRIGHT ASSEMBLY

Determine from the floor plan how many row end upright assemblies will be required. For each one, attach a pair of side sway braces to two angle posts. The brace bolts on the inside of the long flange. Refer to pages 10 and 11 for the approximate, proper* location of the braces. Repeat this procedure until all row ends are assembled.

*Pre-determine critical shelf location to avoid interference with the sway brace bolts.

NOTE: ALL BACK AND SIDE SWAY BRACES ARE ATTACHED TO UPRIGHTS AT 30" VERTICAL SPACING.

Attach side sway braces to posts with 1/4-20 x 3/4" hex head cap screws and hex nuts.

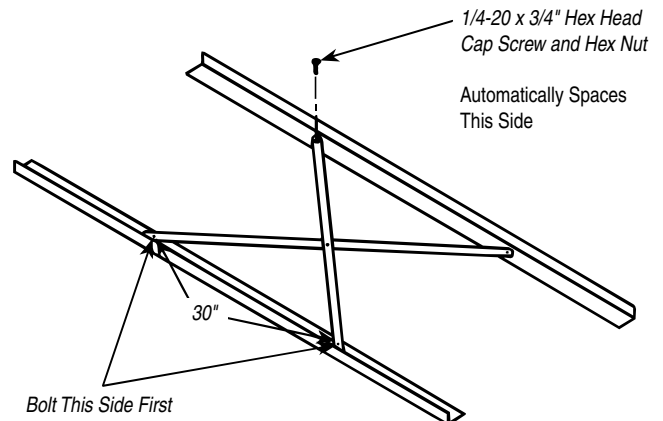

STEP 3 INTERMEDIATE UPRIGHT ASSEMBLY

Determine from the floor plan how many intermediate upright assemblies will be required. Each intermediate consists of four angle posts and one pair of side sway braces. Bolt two posts together (through the fourth hole from each end, in the long flange) to form a T post. Repeat with the other two posts. The two T posts and the side brace are now bolted together at the same level and spacing as the row end upright assemblies (refer to Step 2). Repeat this procedure until all intermediates are assembled.

Attach side sway braces to posts with 1/4-20 x 3/4" hex head cap screws and hex nuts.

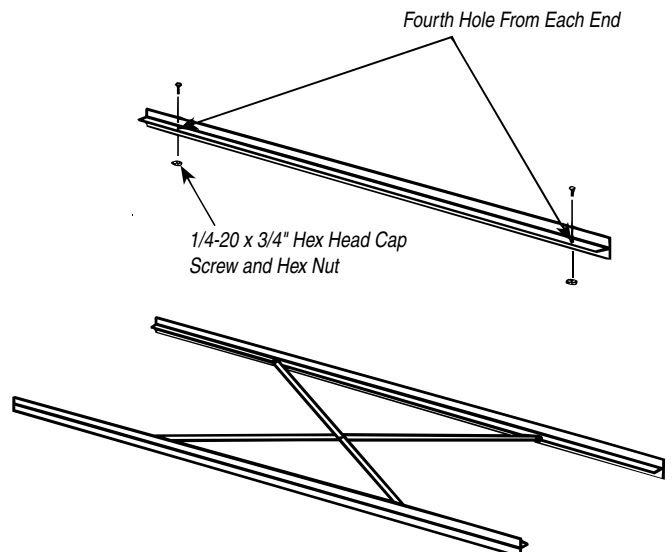

STEP 4 SINGLE ROW - SINGLE FACE ASSEMBLY

In assembly of a single row - single face, begin with a row end upright assembly, a back sway brace and an intermediate upright assembly. The brace bolts to the row end and the intermediate at the same level and spacing as the previously installed side braces. (Steps 2 and 3). The brace bolts on the inside of the short flange.

DO NOT TIGHTEN BOLTS!

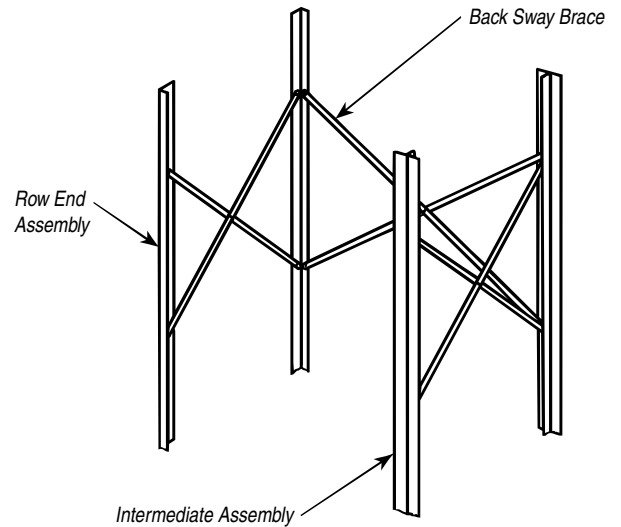

STEP 4A DOUBLE ROW - DOUBLE FACE ASSEMBLY

In assembly of a double row - double face, begin with two row end upright assemblies, a back sway brace and two intermediate upright assemblies. Bolt the two row ends together and then bolt the two intermediates together - each in the fourth hole from the ends. Two legs of the back brace are now bolted on the inside of the short flanges of each upright at the same level and spacing as the previously installed side braces. (Steps 2 and 3).

DO NOT TIGHTEN BOLTS!

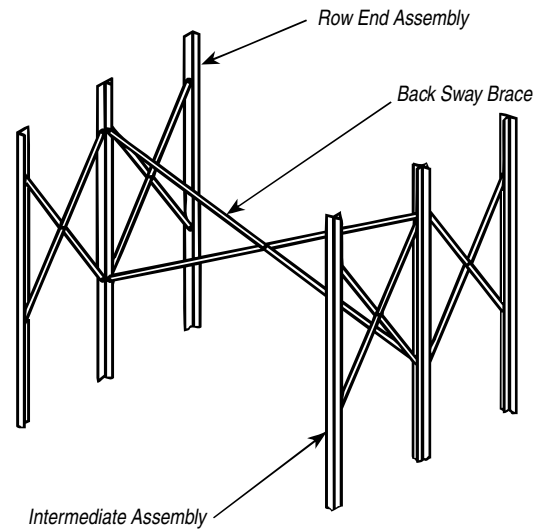

STEP 5 BASE STRIP ATTACHMENT

If a base strip is used, bolt it into place behind the front of the upright assemblies, as shown. The four bottom shelf clips are hung and the bottom shelf is set in place. The top shelf should now be installed using clips in the back and bolts through the front face of the upright and shelf. If a base strip is not used, install bottom shelf in same manner as top shelf.

NOTE: ONE FACE EDGE OF SHELF IS PLAIN (UNPUNCHED) FOR AESTHETICS AND ONE FACE EDGE IS PUNCHED TO ACCEPT FULL-WIDTH SHELF LABEL HOLDERS.

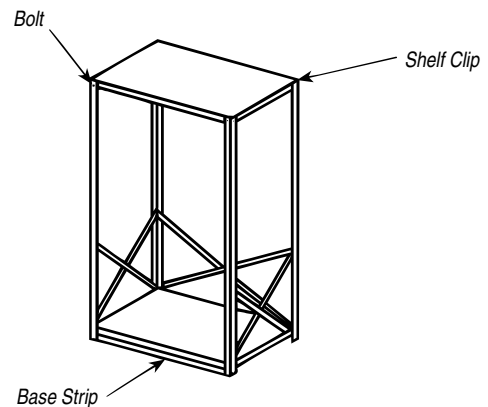

STEP 6 ROW ASSEMBLY

Continue adding intermediate upright assemblies and back sway braces until row is complete, finishing off row with a row end upright assembly. Add the base strips, if used, and as in Step 5, the top and bottom shelves to each section.

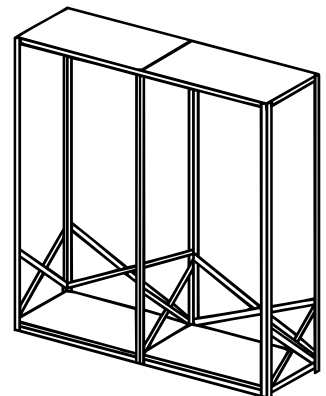

STEP 7 SECTION LEVELING

When required, level sections with shims to cause each upright assembly to be plum within 1/10 inch per foot of height, up to and including 10' high units. For units higher than 10', maximum out-of-plumbness should not exceed 1".

FAILURE TO LEVEL SECTION COULD RESULT IN SHELVING COLLAPSE, PERSONAL INJURY AND/OR COMMODITY LOSS.

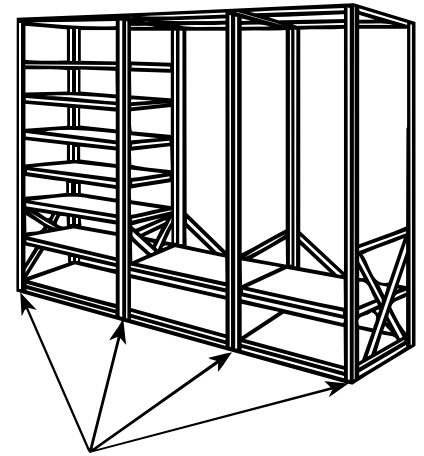

Shims - Front and/or Rear

STEP 8 TIGHTEN ALL BOLTS

Tighten all bolts and add the intermediate shelves to complete the sections.

CLOSED TYPE SHELVING

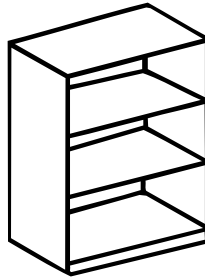

STEP 1 ROW END - CLOSED UPRIGHT ASSEMBLIES

After the material has been distributed to the proper location, determine from the floor plan how many row end - closed upright assemblies and intermediate - closed upright assemblies will be required. The row ends exist as received, two angle posts welded to a side panel. Set aside the required amount.

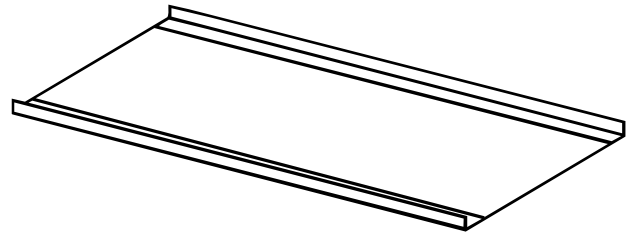

STEP 2 INTERMEDIATE - CLOSE UPRIGHT ASSEMBLY

Assemble the intermediate - closed upright assemblies by bolting two* angle posts to the closed upright assemblies to form a T (bolt through the fourth hole from each end). Repeat this procedure until all intermediates are assembled.

*One angle post is required when a beaded post - closed side is being used.

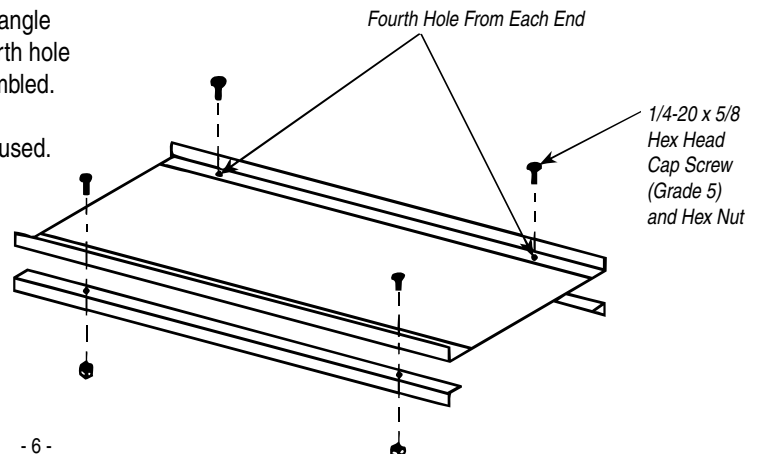

STEP 3 SINGLE ROW - SINGLE FACE ASSEMBLY

In assembly of a single row - single face, begin with a row end - closed upright assembly, a back and an intermediate - closed upright assembly. The back bolts inside the angle post flanges, on both the row end and the intermediate, at the fourth hole from each end and at two medial* points.

DO NOT TIGHTEN BOLTS!

*Pre-determine critical shelf location to avoid interference with back bolts.

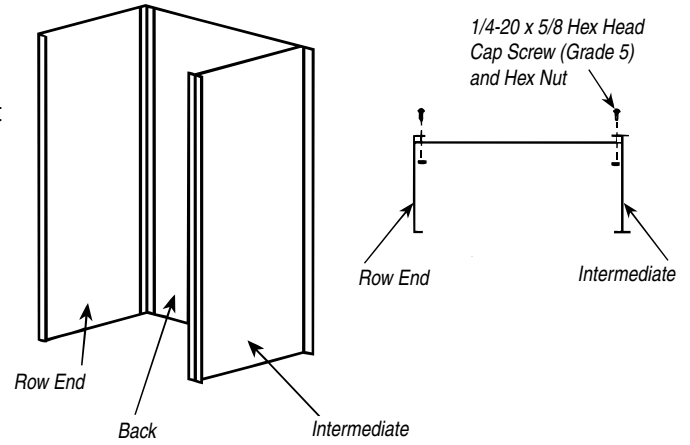

STEP 3A DOUBLE ROW - DOUBLE FACE ASSEMBLY

In assembly of a double row - double face, begin with two row end - closed upright assemblies, a back and two intermediate - closed upright assemblies. Bolt one side of the back between the angle post flanges of the row ends and the other side between the angle post flanges of the intermediates. In both instances, bolt through the fourth hole from each end and at two medial* positions.

DO NOT TIGHTEN BOLTS.

*Pre-determine critical shelf locations to avoid interference with back bolts.

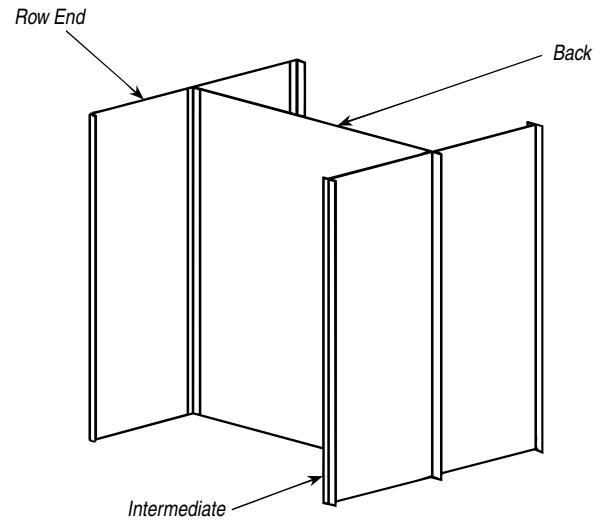

STEP 4 BASE STRIP ATTACHMENT

If a base strip is used, bolt it into place behind the front flanges of the upright assemblies, as shown. The four bottom shelf clips are hung and the bottom shelf is set in place. The top shelf should now be installed using clips in the back and bolts through the front face of the upright and shelf. If a base strip is not used, bolt the bottom shelf in place.

NOTE: ONE FACE EDGE OF SHELF IS PLAIN (UNPUNCHED) FOR AESTHETICS AND ONE FACE EDGE IS PUNCHED TO ACCEPT FULL-WIDTH SHELF LABEL HOLDERS.

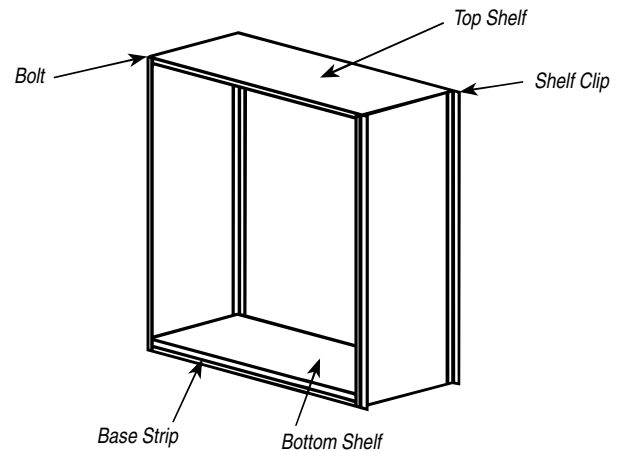

STEP 5 ROW ASSEMBLY

Continue adding intermediate - closed upright assemblies and backs until row is complete, finishing off row with a row end - closed upright assembly. Add the base strips, if used, and the top and bottom shelves to each section.

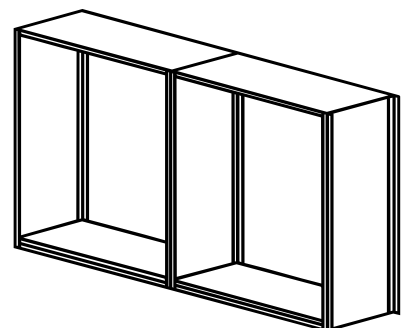

STEP 6 SECTION LEVELING

Where required, level sections with shims to cause each upright assembly to be plum within 1/10" inch per foot of height.

**FAILURE TO LEVEL SECTIONS COULD RESULT IN
SHELVING COLLAPSE, PERSONAL INJURY
AND/OR COMMODITY LOSS.**

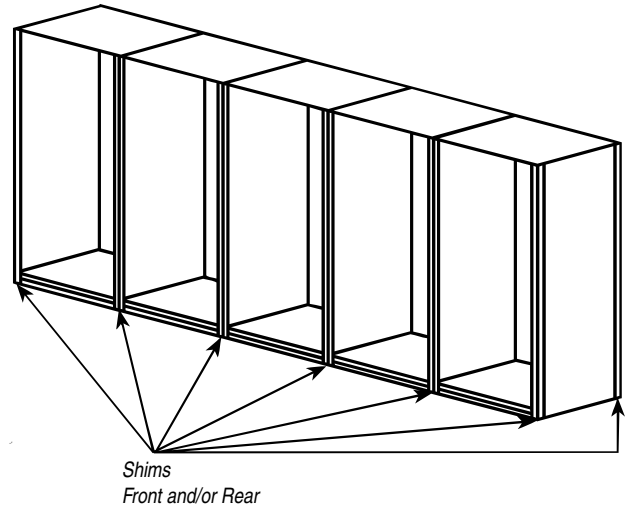

STEP 7 TIGHTEN ALL BOLTS

Tighten all bolts and add the intermediate shelves to complete the sections.

MAJOR ACCESSORIES

LEDGE TYPE SHELVING

Ledge sections, 3'3" high, are bolted to the front of a full height section. The bolts are fastened through the fourth hole from each end.

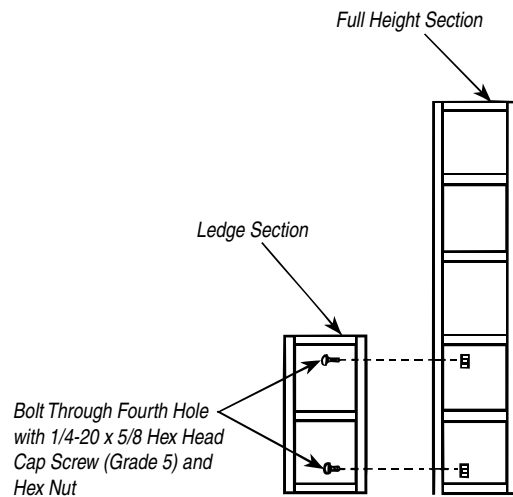

SHELF SIDE SUPPORTS

Tabs hook into front and rear posts in the same manner as shelf clips. Side flange of shelf rests on top flange of shelf side support.

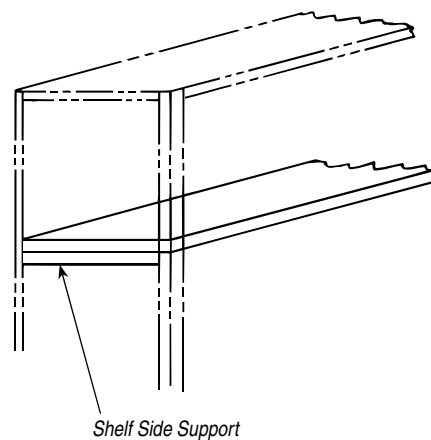

SHELF REINFORCEMENT SADDLES

Install under center of shelf, flanged side up. Turn slightly to clear shelf side flange and then rest on side flanges. Must be used in conjunction with shelf side supports.

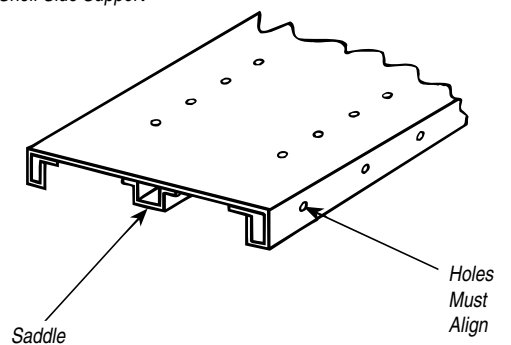

SHELF DIVIDERS - FULL HEIGHT

Install beaded edge toward front. Fasten in place with a snap fastener through hole in divider flange and hole in shelf, both top and bottom. When one divider is installed directly above or directly below another divider, one fastener per hole will hold both dividers.

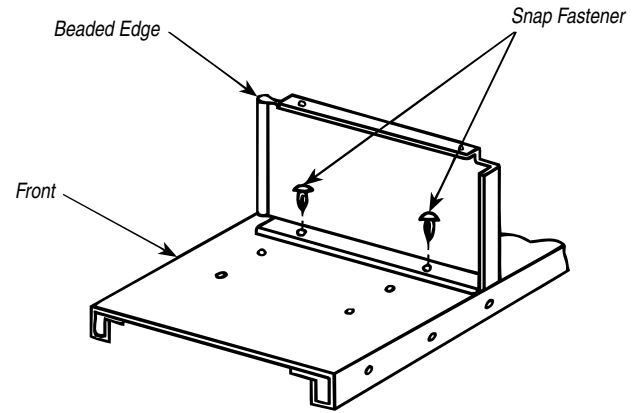

BIN FRONTS and CLIPS

Install behind front flange of posts.

1-1/2" high bin fronts are supplied with clips which slide behind beads and hook over post flange.

3" and 6" high bin fronts are generally bolted to post front flange (hardware furnished) or, optional bolt-on clips may be used.

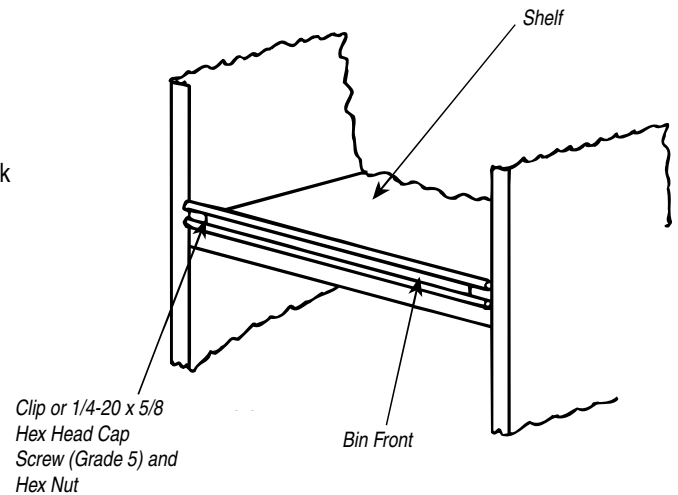

SWAY BRACING RECOMMENDATIONS

FOR UNITS 99" HIGH and LESS

Single Row	
No. Units	8 7 6 5 4 3 2 1
No. Braces	10 9 8 7 6 5 4 3

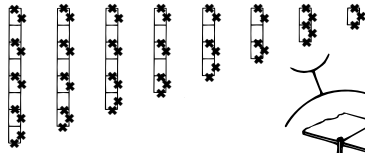

Fig. 1

Double Row	
No. Units	16 14 12 10 8 6 4 2
No. Braces	16 14 13 11 10 8 6 3

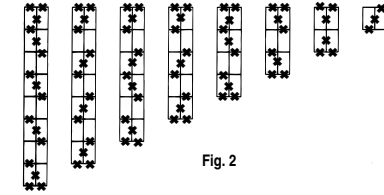
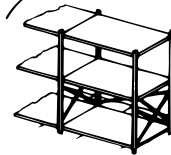

Fig. 2



NOTE:
FOR CRITICAL SHELF LOCATIONS, MINOR CHANGES
TO THESE RECOMMENDATIONS ARE ACCEPTABLE.

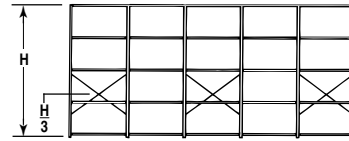

Fig. 3
Back Brace

Light Loading

Both single and double rows may use sway braces as in Figures 1 and 2. The end and back of the first and last section of each row always contains a sway brace. Every other intermediate and every other back should contain a sway brace. The height location of the sway brace is determined as in Figure 3, where the center line of the cross is "height divider by 3" up from the bottom.

Standard Loading

For rigidity in standard duty applications, a pair of sway braces should be put in every opening at the heights illustrated in Figure 4. Each open end should be braced as illustrated in Figure 4A.

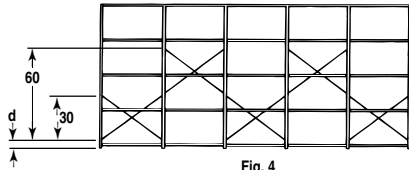

Fig. 4
Back Brace

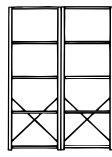

Fig. 4A
Side Brace

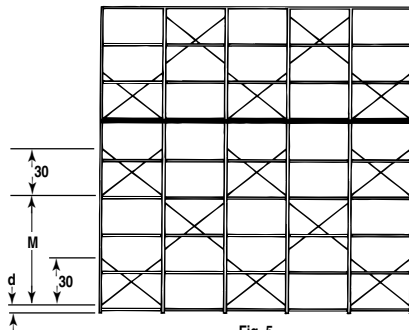

Fig. 5
Back Brace

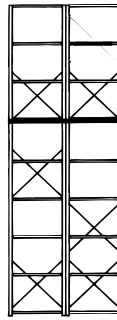

Fig. 5A
Side Brace

Connection point as close as possible to mezzanine level- may be either above or below level.

M = maximum distance possible - up to and including 30"

d = minimum reasonable distance (e.g. 4.5" - 6.0")

Multi-level Application

For rigidity in mezzanine applications, two sway braces should be put in every other opening at the heights illustrated in Figure 5. The intervening openings should be braced with one pair of sway braces as shown. The term "d" equals the distance for mounting the sway braces to the post from the floor. Bolt the front of the center shelf and the front of the top shelf and the base strip in place. The open ends should be braced as illustrated in Figure 5A.

FOR UNITS OVER 99" HIGH

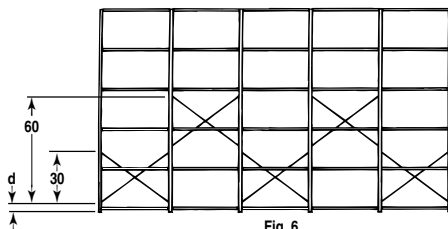

Fig. 6
Back Brace

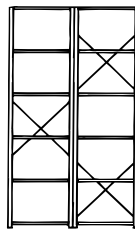

Fig. 6A
Side Brace

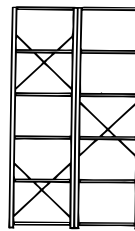

Fig. 6B
Side Brace

NOTE:
FOR CRITICAL SHELF LOCATIONS, MINOR CHANGES TO THESE RECOMMENDATIONS ARE ACCEPTABLE.

Light Loading

For rigidity, Borroughs recommends that one pair of sway braces be installed in each open end and open back. Sway brace height is as shown in Figure 6. Figure 6A and 6B are an end and an intermediate, respectively. The bracing patterns are opposite each other and should alternate from one end of a row down to the other end. Pre-assembly of the two uprights is identical.

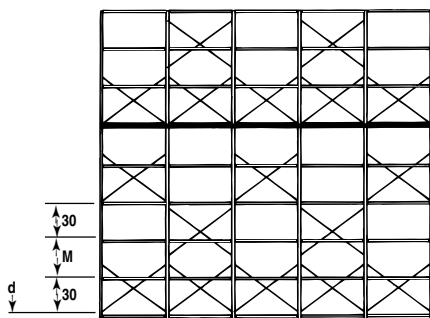

Fig. 7
Back Brace

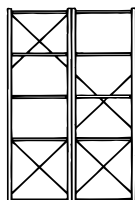

Fig. 7A
Side Brace

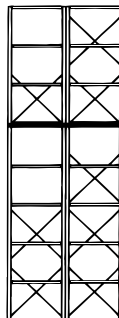

Fig. 7B
Side Brace

Connection point as close as possible to mezzanine level- may be either above or below level.

M = maximum distance possible - up to and including 30"

d = minimum reasonable distance (e.g. 4.5" - 6.0")

Standard Loading and Multi-level

For rigidity, Borroughs recommends that sway braces be used in open backs as illustrated in Figure 7. Sway brace height is as shown in Figure 7. Bolt the front of the center shelf and the front of the top shelf and the base strip in place. Sway bracing for the ends of sections should be installed as shown in Figure 7A for heavy-duty and Figure 7B for multi-level applications.

SEISMIC RISK MAP

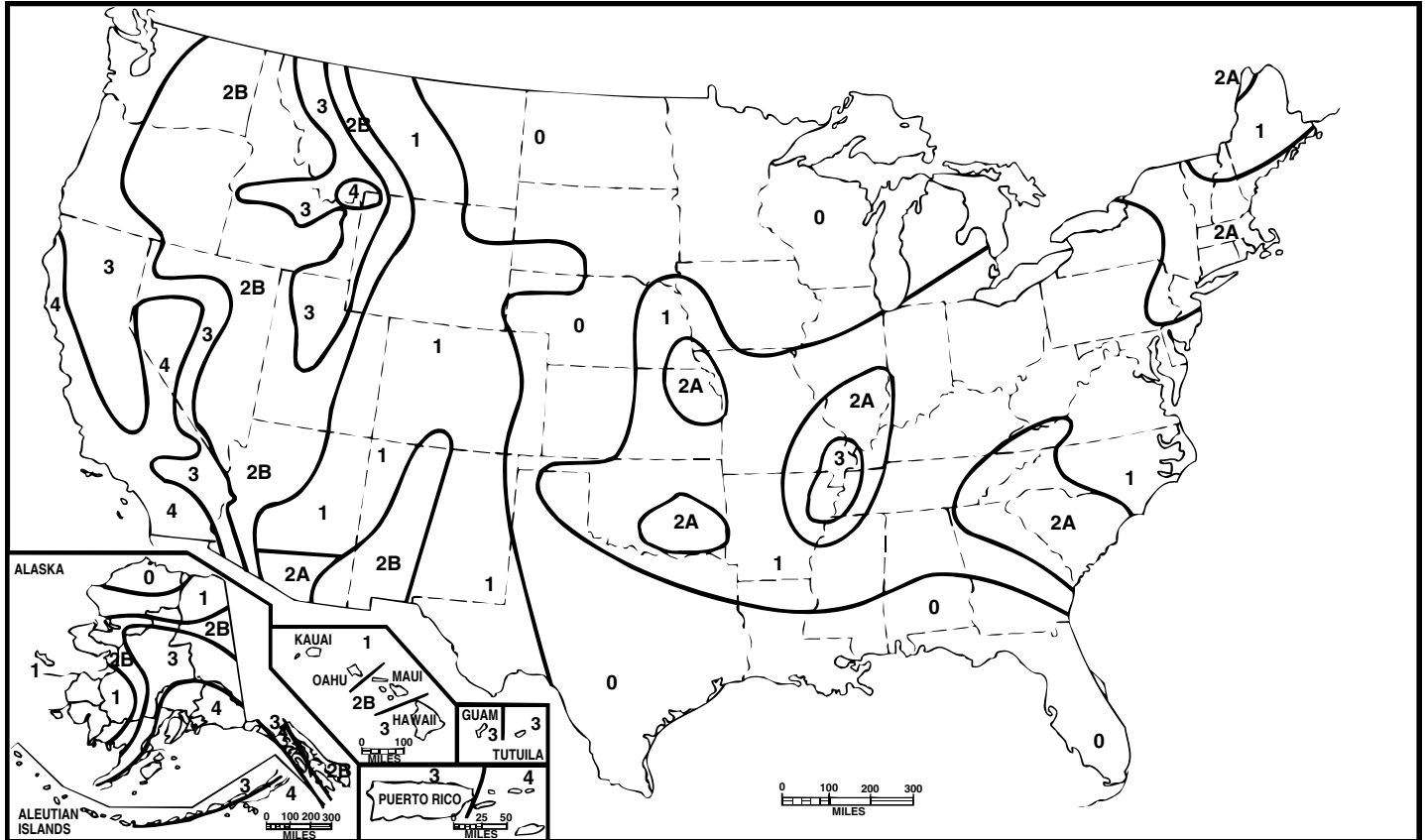

Reproduced from the 1997 edition of the Uniform Building Code™, copyright® 1997, with the permission of the publisher, the International Conference of Building Officials. ICBO and Borroughs assume no responsibility for the accuracy or the completion of summaries provided herein.

All areas of the United States have been zoned seismically. Each zone indicates the anticipated intensity or severity of a seismic occurrence within that region. Zones range from 0 (least likely) to 4 (most likely) to experience damage.

NOTE: Special care should be taken when specifying any system in a highly seismic area.

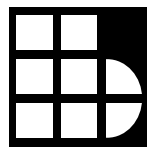

Borroughs
CORPORATION

3002 N. BURDICK STREET ■ KALAMAZOO, MI 49004-3483
800-748-0227 ■ FAX: 269-342-4161 ■ www.borroughs.com